

Product datasheet

Specifications



Interface plug-in relay, 12 A, 1 CO, 120 V AC

RSB1A120F7

Main

Range of product	Harmony Electromechanical Relays
Series name	Interface relay
Product or component type	Plug-in relay
Device short name	RSB
Contacts type and composition	1 C/O
Contact operation	Standard
[Uc] control circuit voltage	120 V AC 50/60 Hz
[Ithe] conventional enclosed thermal current	12 A at -40...40 °C
status LED	Without
control type	Without push-button

Complementary

Shape of pin	Flat (PCB type)
average coil resistance	8360 Ohm network: AC at 20 °C +/- 10 %
[Ue] rated operational voltage	96...180 V AC 50/60 Hz
[Ui] rated insulation voltage	400 V conforming to IEC 60947
[Uimp] rated impulse withstand voltage	3.6 kV conforming to IEC 61000-4-5
Contacts material	Silver alloy (AgNi)
[Ie] rated operational current	12 A (AC-1/DC-1) NO conforming to IEC 6 A (AC-1/DC-1) NC conforming to IEC
minimum switching current	10 mA
Maximum switching voltage	250 V DC conforming to IEC
minimum switching voltage	12 V
Maximum switching capacity	3000 VA/336 W
resistive rated load	12 A at 250 V AC 12 A at 28 V DC
Minimum switching capacity	120 mW at 10 mA, 12 V
Operating rate	<= 600 cycles/hour under load <= 18000 cycles/hour no-load
Mechanical durability	10000000 cycles
Electrical durability	100000 cycles, 12 A at 250 V, AC-1 NO 100000 cycles, 6 A at 250 V, AC-1 NC

Price is "List Price" and may be subject to a trade discount – check with your local distributor or retailer for actual price.

Operating time	20 ms operating 20 ms reset
average coil consumption	0.75 VA AC
Drop-out voltage threshold	$\geq 0.15 U_c$ AC
Safety reliability data	B10d = 100000
Protection category	RT I
Test levels	Level A group mounting
Operating position	Any position
Product weight	0.014 kg
Sale per indivisible quantity	10
Device presentation	Complete product

Environment

Dielectric strength	1000 V AC between contacts 2500 V AC between poles 5000 V AC between coil and contact
Standards	IEC 61810-1 CSA C22.2 No 14 UL 508
Product certifications	UL CSA EAC
Ambient air temperature for storage	-40...85 °C
Vibration resistance	+/- 1 mm (f= 10...55 Hz) conforming to IEC 60068-2-6
IP degree of protection	IP40 conforming to IEC 60529
Shock resistance	10 gn (duration = 11 ms) for not operating conforming to IEC 60068-2-27 5 gn (duration = 11 ms) for in operation conforming to IEC 60068-2-27
Ambient air temperature for operation	-40...70 °C (AC)

Packing Units

Unit Type of Package 1	PCE
Number of Units in Package 1	1
Package 1 Height	2.100 cm
Package 1 Width	2.500 cm
Package 1 Length	31.100 cm
Package 1 Weight	13.000 g
Unit Type of Package 2	BB1
Number of Units in Package 2	10
Package 2 Height	1.500 cm
Package 2 Width	2.800 cm
Package 2 Length	33.000 cm
Package 2 Weight	142.000 g
Unit Type of Package 3	S01
Number of Units in Package 3	350
Package 3 Height	15.000 cm

Package 3 Width	15.000 cm
-----------------	-----------

Package 3 Length	40.000 cm
------------------	-----------

Package 3 Weight	5.200 kg
------------------	----------

Contractual warranty

Warranty	18 months
----------	-----------



Environmental Data

Schneider Electric aims to achieve Net Zero status by 2050 through supply chain partnerships, lower impact materials, and circularity via our ongoing “Use Better, Use Longer, Use Again” campaign to extend product lifetimes and recyclability.

[Environmental Data explained >](#)

[How we assess product sustainability >](#)

Environmental footprint

Carbon footprint (kg.eq.CO2 per CR, Total Life cycle) 7

Environmental Disclosure [Product Environmental Profile](#)

Use Better

Materials and Substances

Packaging made with recycled cardboard Yes

Packaging without single use plastic Yes

SCIP Number 45b41055-6c52-408d-9c0c-5c663b810f29

China RoHS Regulation [China RoHS declaration](#)

Use Again

Repack and remanufacture

Circularity Profile No need of specific recycling operations

WEEE  The product must be disposed on European Union markets following specific waste collection and never end up in rubbish bins

Take-back No

Dimensions Drawings

Dimensions

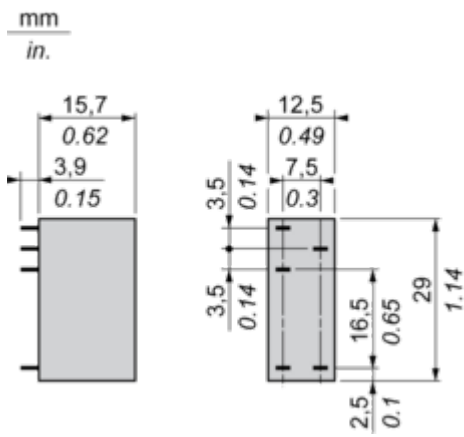

Connections and Schema

Wiring Diagram

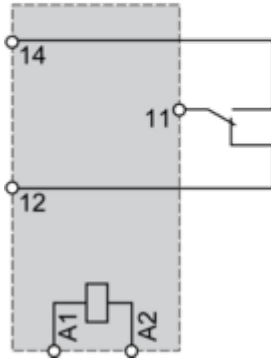
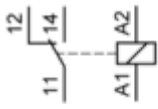

NOTE: For DC input, A1 have to be +, otherwise it would short circuit from protection module

Performance Curves

Electrical Durability of Contacts

Durability (inductive load) = durability (resistive load) x reduction coefficient.

Resistive AC load

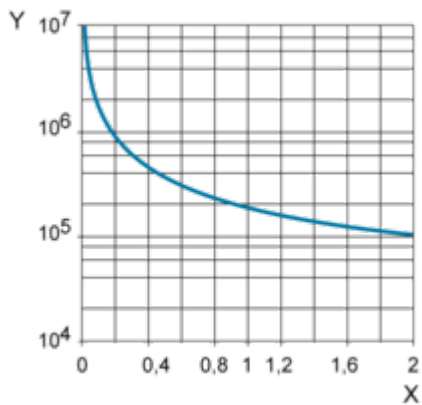

X Switching capacity (kVA)

Y Durability (Number of operating cycles)

Reduction coefficient for inductive AC load (depending on power factor cos φ)

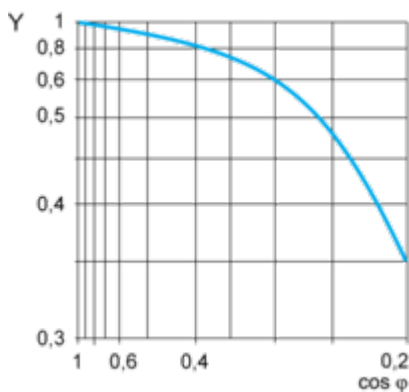

Y Reduction coefficient (A)

Maximum switching capacity on resistive DC load

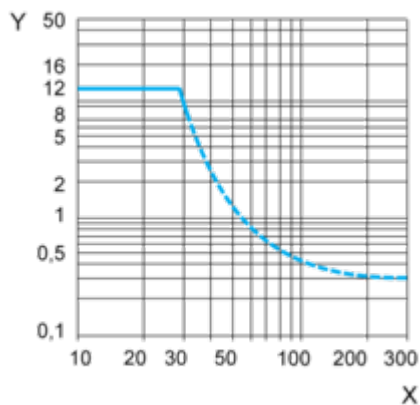

X Voltage DC

Y Current DC

Note : These are typical curves, actual durability depends on load, environment, duty cycle, etc.

Technical Illustration

Dimensions

mm
in.

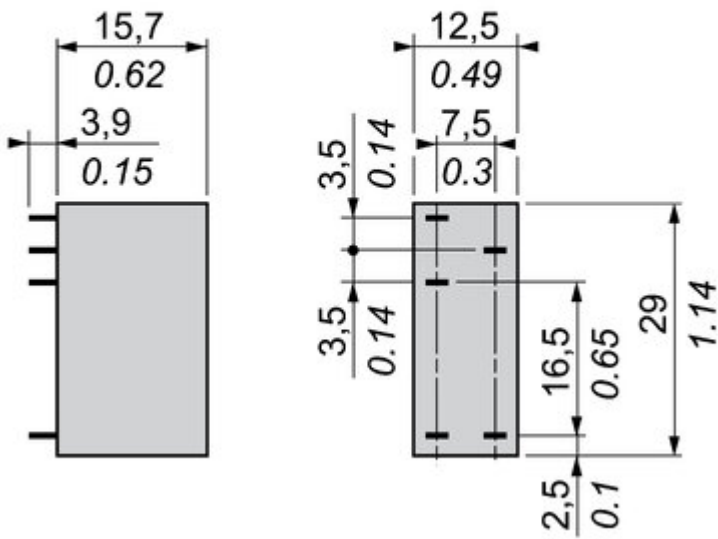

Image of product / Alternate images

Alternative

